



Since 1947

Flanged Immersion Heaters

Process Heating Company's (PHCo) Flanged Immersion Heaters are perfect for use in tanks, large vats and reservoirs.

These heaters consist of a standard 150# or 300# flange for mounting and PHCo's exclusive heating elements. The elements are "dry well" and "low density" design.



The dry wells allow the elements to be serviced or replaced without draining the tank, a huge advantage if maintenance is required. The low watt density design keeps the element sheath temperature low, reducing the chance of coking or build up on the heater.

The flange and heater tubes can be made of mild steel or various grades of stainless steel depending on your application. These direct immersion heaters are virtually 100% efficient (all the energy consumed is transferred to your process) and easily controlled.

The heaters can be supplied either with our custom, U.L. Listed industrial control panels integrally mounted and wired to the heaters or without if controls are already present. Flanged Immersion Heaters are one of the most widely used methods of heating liquids. PHCo offers many advantages over traditional style tubular elements.

Features

- **Flange/Heater Materials** – mild steel and various grades of stainless steel
- **Sheath Thickness** – up to .300" wall thickness for durability and corrosion resistance
- **Flange Sizes** – 3" up to 36" in 150# or 300# ANSI Raised Face
- **Kilowatt Ratings** – up to 1,000 kW
- **Watt Densities** – up to 20 watts per square inch, less than 10 is standard
- **Voltages Available** – up to 600 VAC, single or 3 phase
- **Immersion Length** – up to 20 feet
- **Terminal Enclosure** – Moisture resistant standard. Some sizes available as explosion resistant
- **Open Coil Elements** – Pipe insert type, dry well elements for ease of service

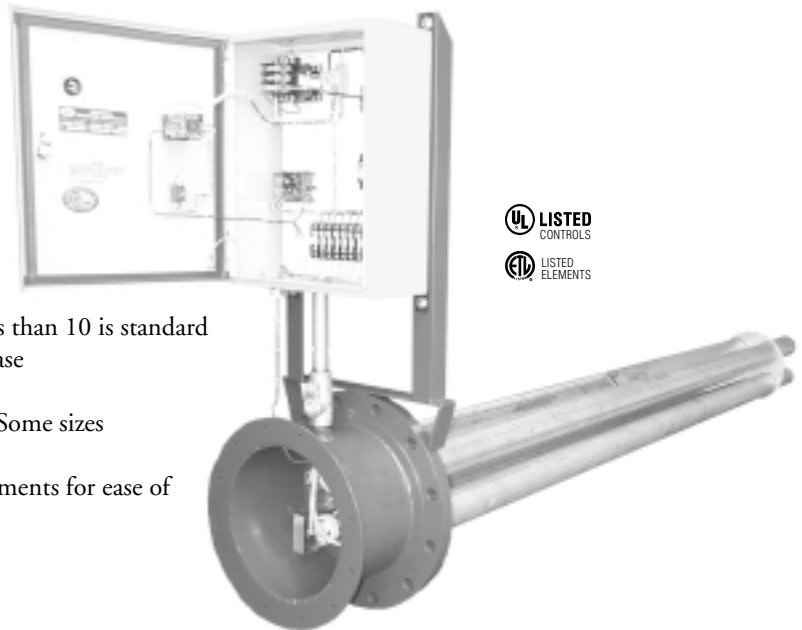

Process Heating
Company, Inc.



Providing industry with efficient, reliable electric
heating systems since 1947

2732 - 3rd Ave. So. • Seattle, WA 98134
P.O. Box 84585 • Seattle, WA 98124
Ph: (206) 682-3414 • Fax: (206) 682-1582
e-mail: inquire@processheating.com
www.processheating.com

Flanged Heater

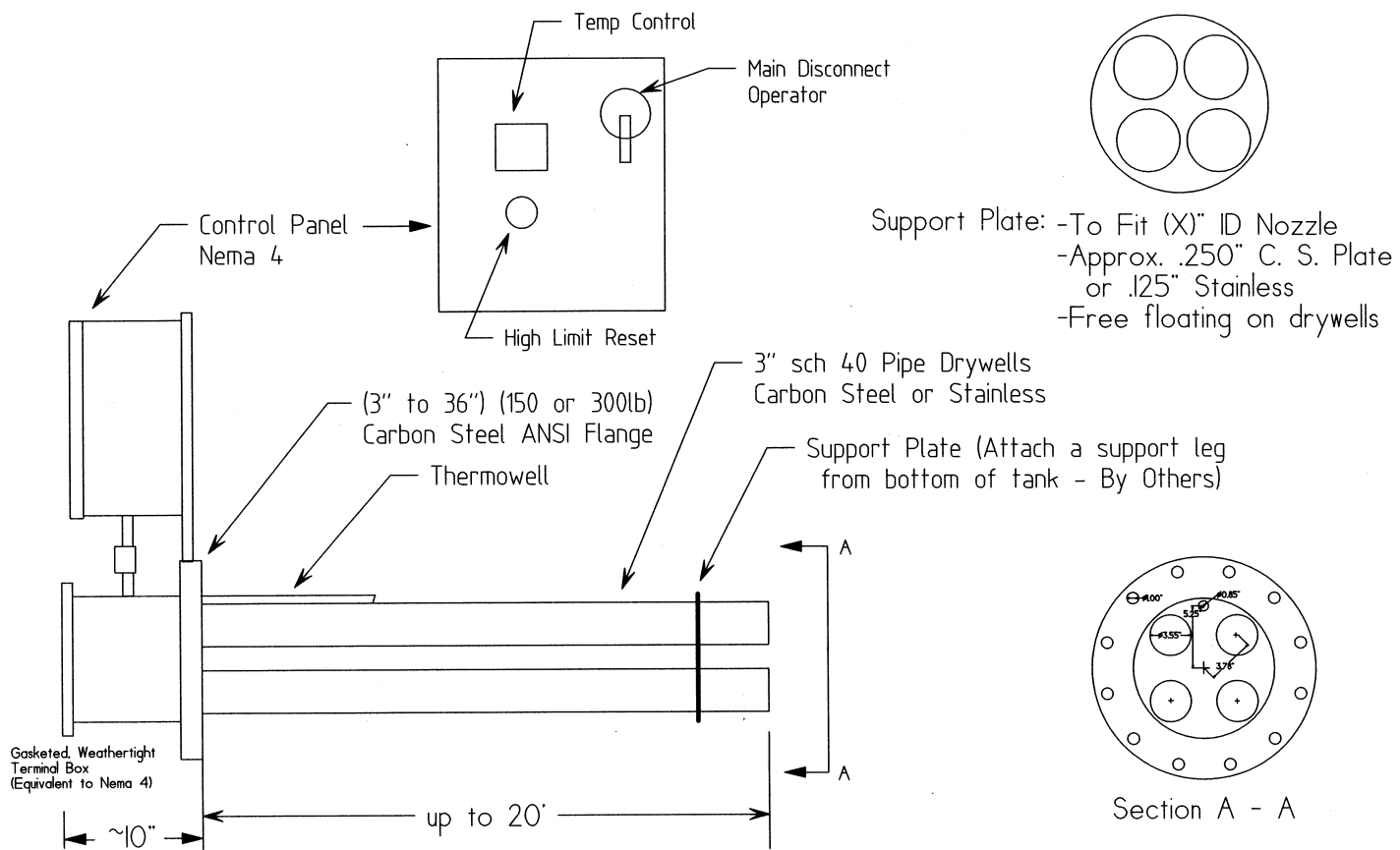

Number of Pipe Drywells varies with flange size